

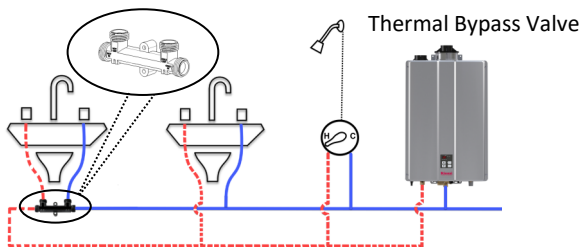

## ■ CIRC-LOGIC RECIRCULATION TECHNOLOGY

Rinnai Circ-Logic recirculation technology allows users to set recirculation patterns that coincide with their hot water usage patterns. Hot water is available when needed, without the expense of circulating it during times of inactivity. Two recirculation modes are available:

- **Dedicated Mode** - With a dedicated return line, the integrated pump recirculates water from the tankless water heater through the return line and back to the heater.
- **Crossover Mode** - In applications where a dedicated return line is not available or is difficult to install, Circ-Logic technology allows for the simple installation of a **Thermal Bypass Valve** (included with purchase) at the fixture farthest away from the water heater.



## Smart-Circ™

Intelligent Recirculation™

- Intelligent Recirculation “learns” users’ hot water patterns to schedule recirculation.

## ■ EASE OF INSTALLATION AND SERVICEABILITY

- Compact Design to Save Space
- Wi-Fi Technology for Remote Monitoring, Management and Recirculation Control.
- Improved Gas Conversion

### HIGH-EFFICIENCY (NON-CONDENSING) TANKLESS WATER HEATER

<b>Installation Type</b>	Internal (Indoor) Residential Applications. Manufactured (Mobile) Home Certified	
<b>Model Numbers</b>	REP199i (REU-VEP2730FFD-US) REP160i (REU-VEP2125FFD-US)	
<b>Approved Gas Types</b>	Natural and Propane	
<b>Efficiency</b>		UEF: 0.82 (REP199i) 0.81 (REP160i)
<b>High Altitude Approved</b>	Up to 10,200 ft (3,109 m)	
<b>Water Flow Control</b>	Water Flow Sensor, Electronic Water Control and Bypass Control (RE199/RE180 only)	
<b>Controller</b>	Standard: Integrated Controller Optional: MC-195T-US, RWM101 (control•r™), MC601, MCC601	
<b>Certifications</b>	AHRI, ANSI Z21.10.3, CSA 4.3	

### Warranty

- Heat Exchanger: 15 years or 12,000 operation hours, whichever occurs first
- All Other Parts and Components: 5 Years
- Reasonable Labor: 1 Year

### Safety Devices

Flame Failure - Flame Rod, Boiling Protection, Combustion Fan RPM Check, Over Current - Glass Fuse, Remaining Flame (OHS) and Automatic Frost Protection

### Additional Features

- Mobile Home Certified
- Complies with South Coast Air Quality Management District 14 ng/J or 20 ppm NOx Emission Levels
- Ultra Low NOx

## OPTIONAL ACCESSORIES

Room Air Screen, Condensate Neutralizer, ScaleCutter, Drain Down Kit, Additional Controllers, Pipe Cover, Recirculation Pump, DPS/MIS Switch, EZConnect™ Cables, Wireless Accessories, and many more. Visit [rinnai.us](http://rinnai.us) for a complete list of accessories.



CERTIFIED TO ANSI Z21.10.3 — CSA 4.3

# TECHNICAL SPECIFICATIONS

SPECIFICATION		REP199i	REP160i
Dimensions - w, h, d		14.05 in. x 27.3 in. x 11.2 (357 mm x 693 mm x 284 mm)	
Minimum Gas Consumption Btu/h		10,400	
Maximum Gas Consumption Btu/h		199,000	160,000
Flow Rate <sup>1</sup> (Min - Max)		0.26 - 7.9 GPM (1.0 - 30 L/min)	0.26 - 6.6 GPM (1.0 - 25 L/min)
Max Flow Rate with Parameter Adjustment		7.9 GPM (30 L/min)	6.6 GPM (25 L/min)
Activation Flow Rate		0.4 GPM (1.5 L/min)	
Weight		50 lb (22.7 kg)	47 lb (21.3 kg)
Sound Level		55 dB	
Electrical	Normal	96 W	91 W
	Standby	1 W	
	Freeze Protection	86 W	
	Normal with Pump Operation	162 W	160 W
	Max Current	4 Amps	
	Fuse	10 Amps	
Temperature Setting		120°F-140°F (49°C-60°C)	
By-Pass Flow Control		Fixed Bypass	
Gas Supply Pressure <sup>2</sup>		<ul style="list-style-type: none"> <li>Natural: 4.0 in. w.c. - 10.5 in. w.c.</li> <li>Propane: 8.0 in. w.c. - 13.0 in. w.c.</li> </ul>	
Ignition System		Direct Electronic Ignition	
Electronic Connections		<ul style="list-style-type: none"> <li>Appliance: AC 120 Volts, 60Hz.</li> </ul>	
Water Supply Pressure		<ul style="list-style-type: none"> <li>Minimum: 20 PSI (Recommended 30-80 PSI for max performance)</li> <li>Maximum: 150 PSI</li> </ul>	
Service Connections		<ul style="list-style-type: none"> <li>Gas Supply: 3/4 in. (19 mm) NPT</li> <li>Cold Water Inlet: 3/4 in. (19 mm) NPT</li> <li>Hot Water Outlet: 3/4 in. (19 mm) NPT</li> </ul>	
Clearances		<ul style="list-style-type: none"> <li>Top: 2 in. (51 mm)*</li> <li>Bottom/Ground: 12 in. (305 mm)</li> <li>Front: 0 in.*</li> <li>Back: 0 in.</li> <li>Sides: 2 in. (51 mm)**</li> <li>Vent: 0 in.</li> </ul>	

\* 0 in. from vent components

\*\* Clearance for servicing is 24 in. (610 mm) in front of water heater

<sup>1</sup>Minimum flow may vary slightly depending on the temperature setting and the inlet water temperature. Minimum activation flow is 0.4 GPM (1.5 L/min).

<sup>2</sup>The maximum gas supply pressure must not exceed the specified value.

# WATER FLOW CURVE

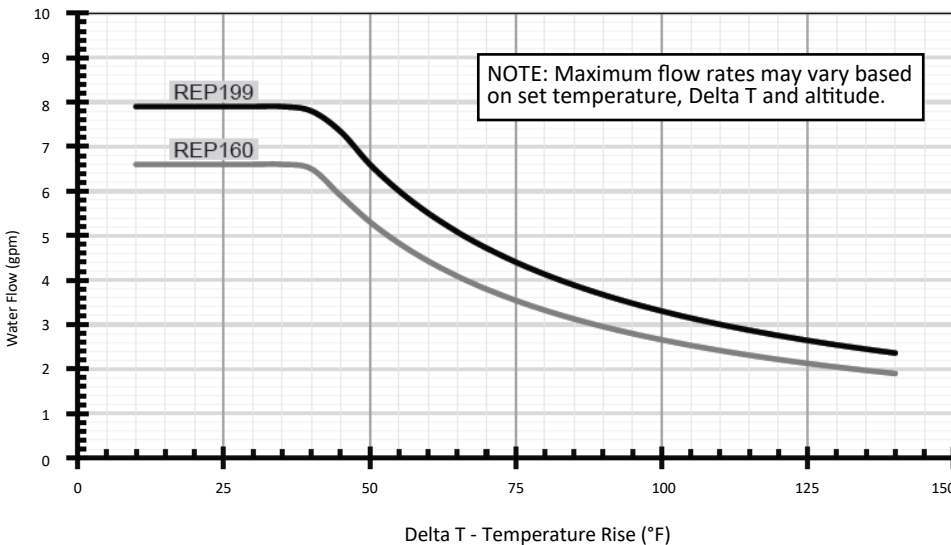

# DIMENSIONS

in. (mm)

## FRONT

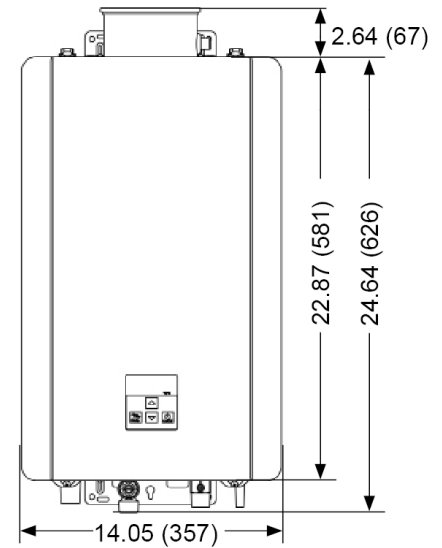

## SIDE

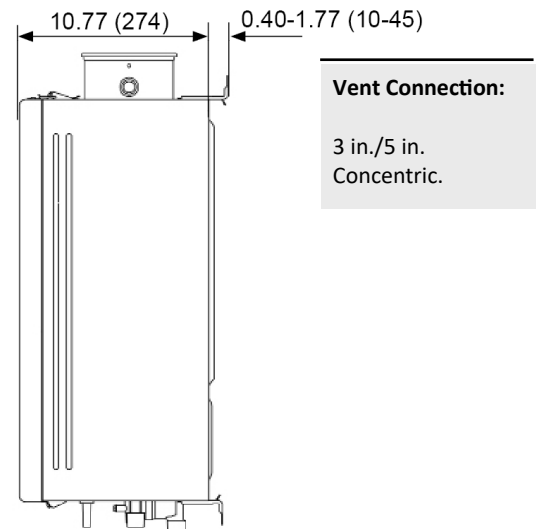

## BOTTOM

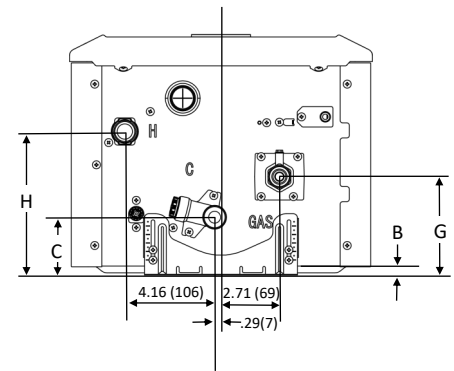

Connection		in.*	mm*	in.**	mm**
COLD	C	2.69	68	4.05	103
HOT	H	6.66	169	8.04	204
GAS	G	4.57	116	5.94	151
Bracket	B	.40	10	1.77	45

\*Wall bracket retracted.

\*\*Wall bracket extended.

## REP199i Pressure Drop Curve (Water Heater + Pump)

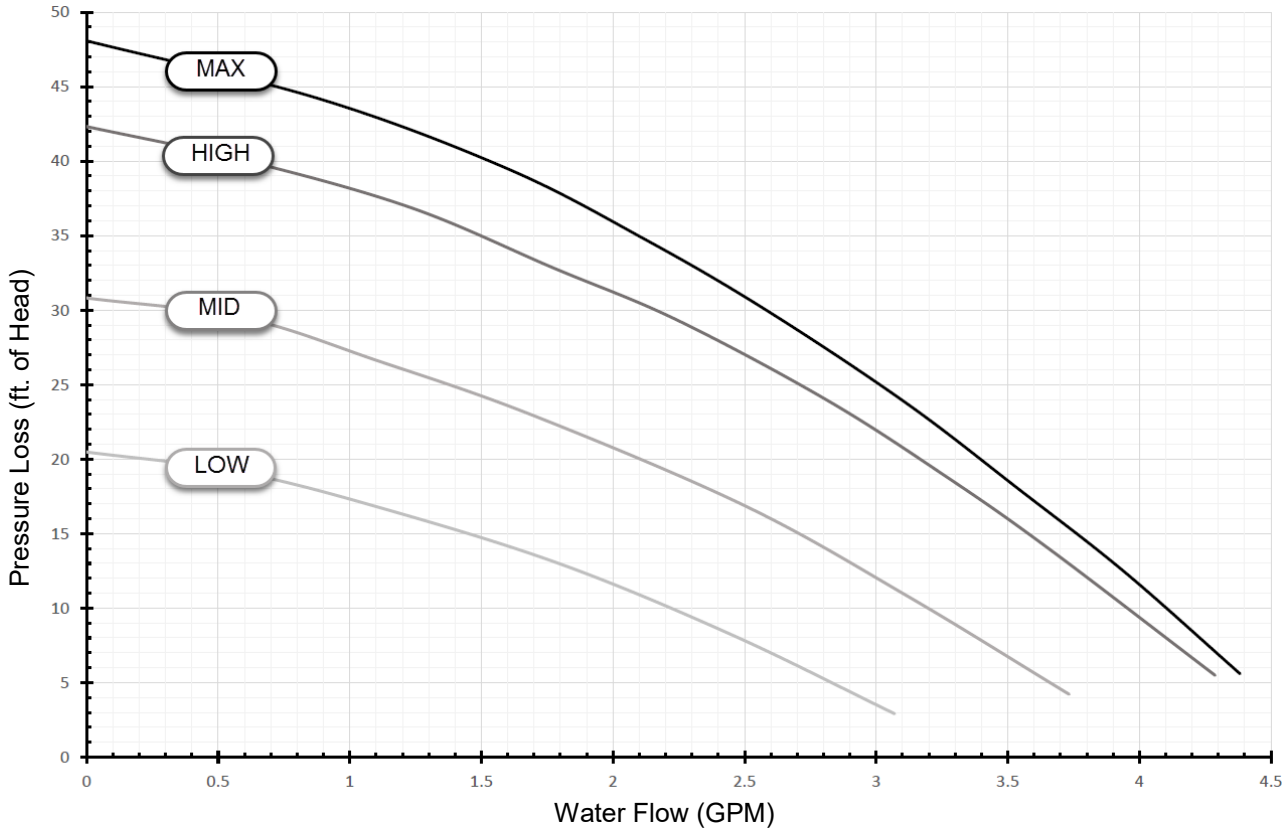

## REP160i Pressure Drop Curve (Water Heater + Pump)

